

DOORSNEDE OP HS (NAAR BB GEZIEN)

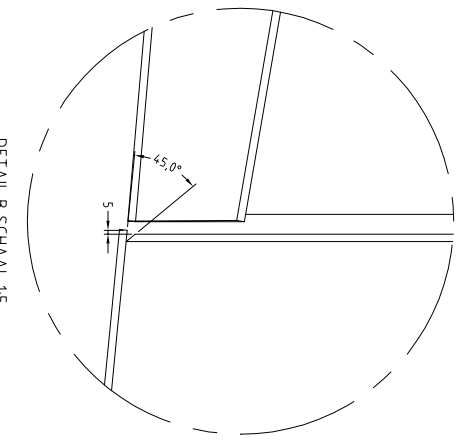
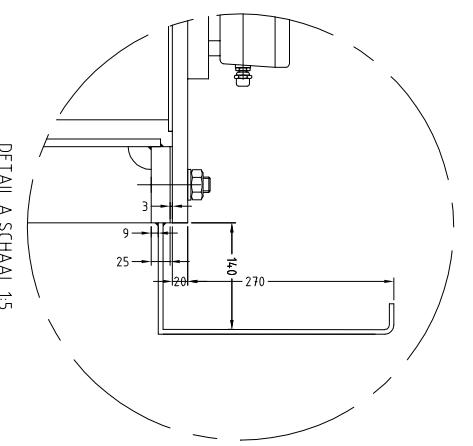
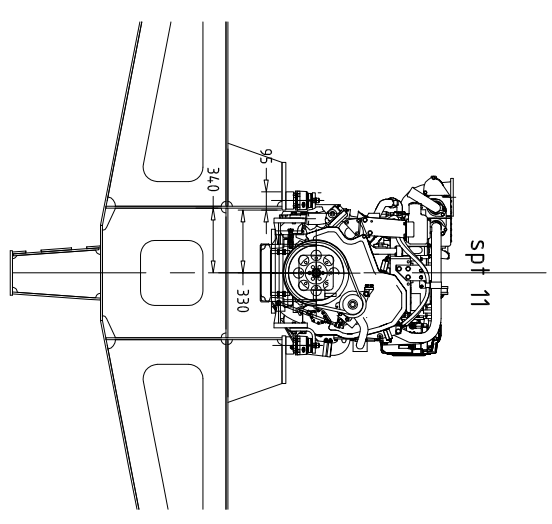
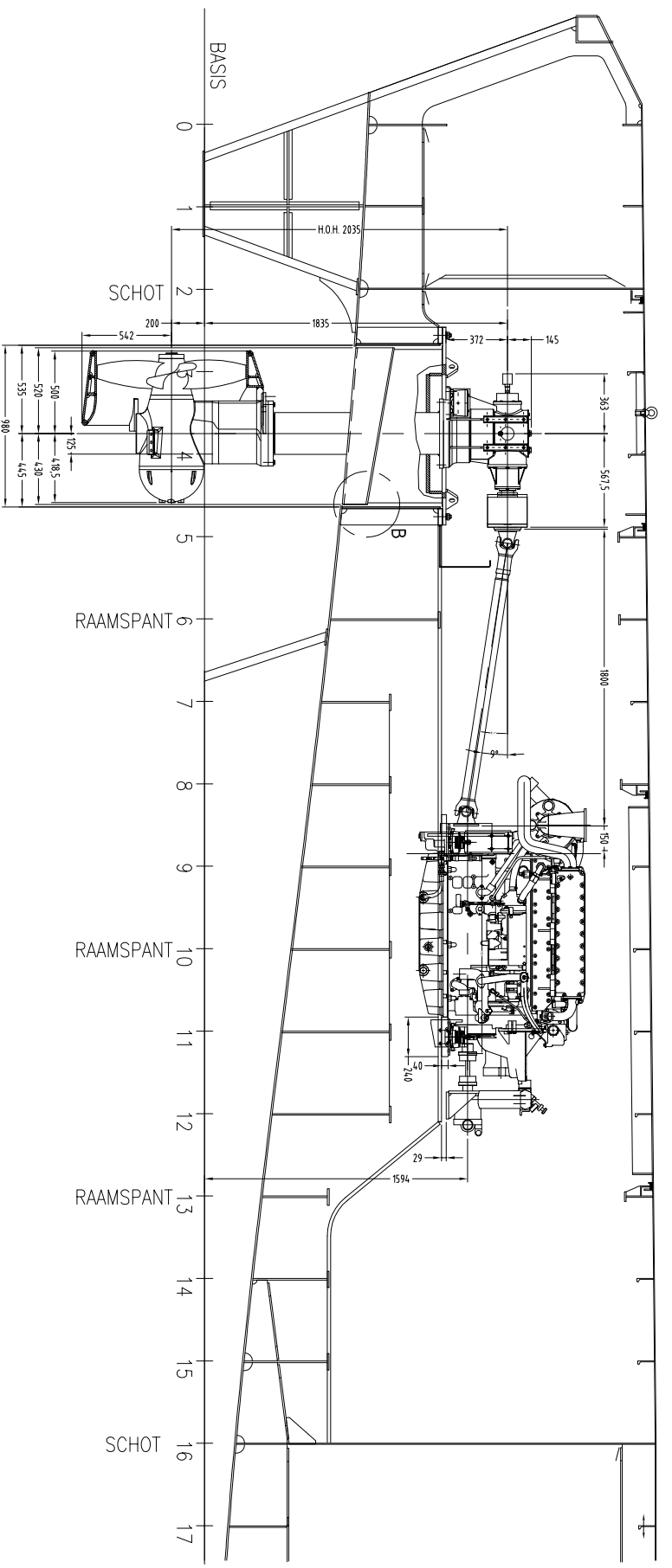
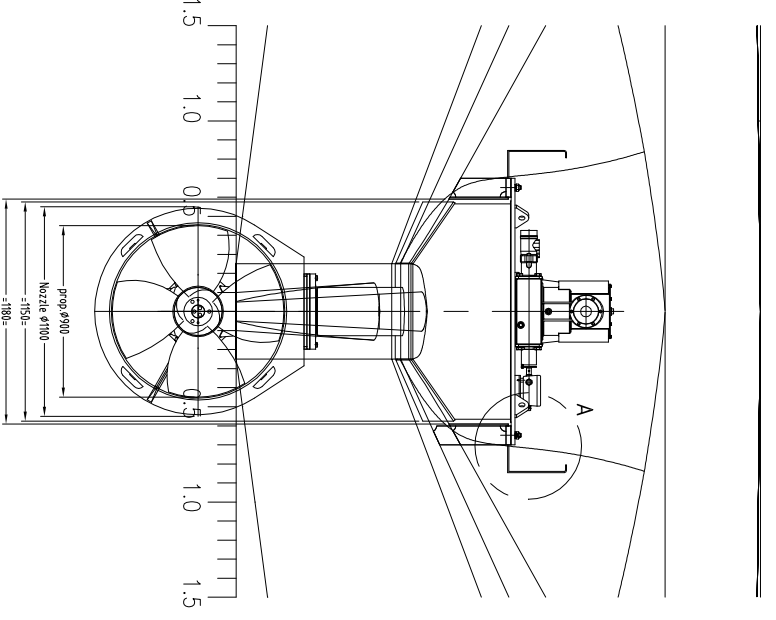

REV.	D.D.	OMSCHRIJVING	NAAM
C	23-06-10	afmeting vulplaten en bovenrand lekrand gezet	BC
CB	13-01-10	MOTORFUNDATIE HOOGTE+HOH AFSTAND	BC
A	10-12-09	VERLAGING MOTORFUNDATIE	RVDW
REV.	D.D.	OMSCHRIJVING	NAAM

IMM-OS	PRODUCENTE	NAAM	D.O.
OPDR. GEVER	KLIJF	NAAM	D.O.
PROJ. L.	KLIJF	NAAM	D.O.
KEUR. DOOR	KLIJF	NAAM	D.O.

GET.	EM	DEELORDER	01
D.D.	10-11-2009	TEK. NR.	162-00-005
GEZ. TK	BC	SCHAAL	1:20
D.D.	11-10-2009	FORMAAT	A-1

<b>Scheepswerf Grave b.v.</b> Westkade 28 5151 GZ Steenbergen Nederland T. 0486 47 24 64 F. 0486 47 24 64 E. info@scheepswerfgrave.com		OPSTELLING VOORTSTUWING
Bouwnr. : 162		

